



The following building code requirements are the current minimum code standards, as taken from the IRC Code & Commentary 2012, required for Safety Glazing in One and Two family dwellings, and based on Kentucky Amendments to the 2013 Kentucky Residential Code, Second Edition, February 2014 Chapter 11, Energy Efficiency.

**Disclaimer:** This is not a listing of all code sections involving building or utilities which involve this subject, but only the sections most often questioned. Refer to the 2013 Kentucky Residential Code book for information not listed in this handout and for other requirements of the building code.

### **A. ENERGY CODE REQUIREMENTS, Windows and Doors**

1. **Location by Climate Zone:** Hardin County per Table N1101.10, and the entire state of Kentucky, is located in Climate Zone 4, the HDD is 4,000 to 4,999.
2. **Chapter 11, Energy Efficiency.** Per N1101. 1, The energy efficiency for the design and construction of buildings shall comply by either meeting the requirements of the *International Energy Conservation Code* or meeting the requirements of this chapter.
3. **Insulation and fenestration criteria.** (N1102.1.1) The building thermal envelope shall meet the requirements based on Climate Zone 4 as specified in Table N1101.2.1.1. **The term fenestration refers to** opaque doors and the light-transmitting areas of a residential building's wall, floor or roof, generally window, skylight, and non-opaque door products.
4. **Fenestration U-Factor.** (Table N1102.1.1) (R402.1.1) Provide Fenestration U-Factor 0.35 maximum. **The lower the U-Factor number the better the window.**

### **B. Safety Glazing Requirements of the 2013 Kentucky Residential Code (R308.1)**

#### **1. Required Glazed Openings**

1. **Glazing Location.** Required glazed openings shall open directly onto the street or public alley, yard or court.(R303.8)
2. **Porches. (R303.8)** Required glazed openings may face onto a roofed porch that abuts street, yard, or court. The long side of the porch shall be a minimum 65% open, and the ceiling height not less than 7 feet.
3. **Sunrooms. (R303.8.1)** Required glazed openings may face onto sunrooms or patio covers that abut street, yard or court. The exterior sunroom walls shall be 40% or enclosed only with insect screening, and the ceiling height not less than 7 feet.
4. **Louvered or Jalousies. (R308.2)** Glass in louvered windows or jalousies shall not be less than 3/16-inch thick or longer than 48 inches. Exposed edges shall be smooth. Wired glass shall not be used in jalousies or louvered windows. (R308.2.1).

#### **2. Hazardous Glass Locations**

- o **Human Impact Loads. (R308.3)** Individual glazed areas, other than louvered windows and jalousies meeting R308.2, and glass mirrors in hazardous locations must comply with CPSC 16 CR. Part 1201 for Category I or II.





Figure 14-15

- o **Label (R308.1)** Each pane of glazing installed in a hazardous location shall be permanently labeled as safety type. (E.g. *Tempered*). Exception for approval by the building official.

**3. Glazing Must be Installed and Labeled in the Following Locations: (R308.4)**

1. **Side Hinged Doors** – All side hinged (swinging) doors except jalousies, decorative glass and glazed openings in which a 3" sphere is unable to pass through.
2. **Sliding Doors** – Fixed and sliding panels of sliding doors and closet door assemblies.
3. **Storm Doors.**
4. **Unframed swinging doors.**
5. **Bath enclosures** – Doors and enclosures for hot tubs, whirlpools, saunas, steam rooms, bathtubs and showers; any part of a building wall enclosing these compartments with a bottom edge less than 60 inches above the floor.

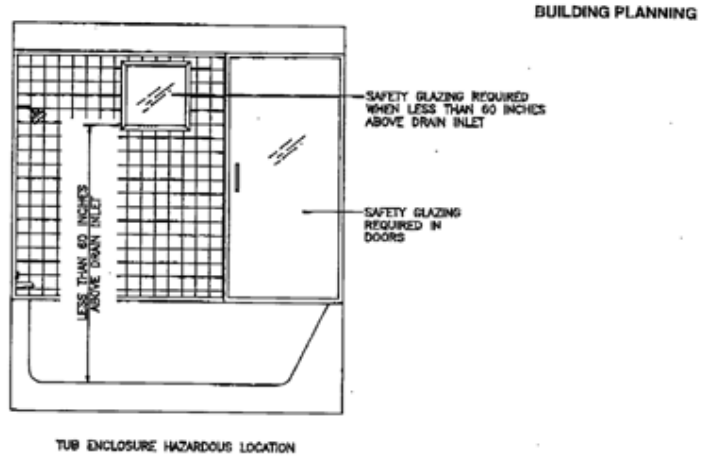

Figure No. 208.4b  
**SAFETY GLAZING IN TUB AND SHOWER ENCLOSURES**

6. **Sidelights adjacent to Doors.** Individual fixed or operable panel, except decorative glass, adjacent to a door with 24 inches of arc and bottom edge that is less than 60 inches above the floor unless there is an intervening barrier between the door and the glazing, or the wall at the swing side is perpendicular, or where the door opens to a closet no more than 3 feet deep.

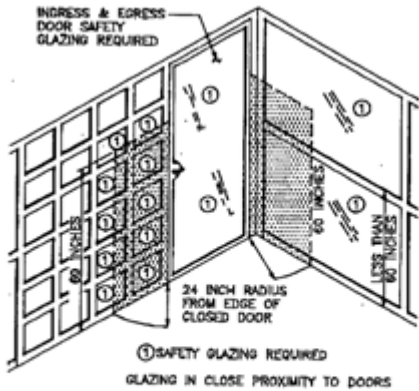

Figure No. 208.4c  
**SAFETY GLAZING IN CLOSE PROXIMITY TO DOORS**

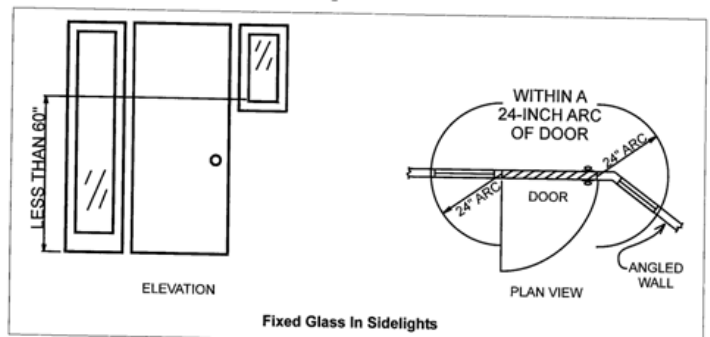
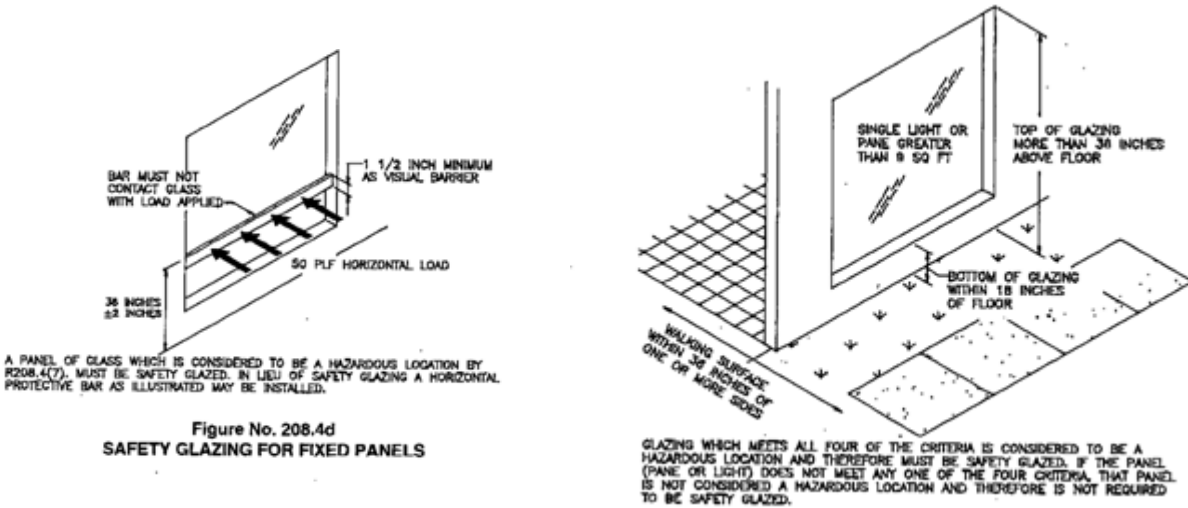

Figure 14-11

7. **Large Individual Panes.** Individual fixed or operable panel other than those in 5 and 6 above, that meet all of the following, except decorative glass or when a 1 ½ inch bar, capable of withstanding a load of 50 pounds per linear foot, is installed on the accessible side of 34 to 38 inches.

**Required Only When All of the Following Conditions are Met (R308.4.3):**

- Exposed area of individual pane exceeds 9 square feet;
- Lowest edge is less than 18 inches above floor;
- Top edge is greater than 36 inches above floor; and
- Walking surfaces within 36 inches horizontally of glazing.



8. **Railings.** All railings including structural baluster panels and non-structural in-fill panels.(R308.4.4)
9. **Pools and Spas.** Walls and fences enclosing indoor and outdoor swimming pools, hot tubs and spas where bottom edge on pool or spa side is less than 60 inches above walking surface and within 60 inches horizontally to water edge. Single and all multiple panes. (R308.4.5)
10. **Adjacent to Walking Surface.** Glazing, other than glass panels complying with IBC 1013 and 1607.7, adjacent to stairways, landings and ramps within 36 inches horizontally of walking surface, with glass less than 60 inches above plane of adjacent walking surface unless a 1 ½ inch bar, capable of withstanding a load of 50 pounds per linear foot, is installed on the accessible side at 34 to 38 inches. (R308.4.5)

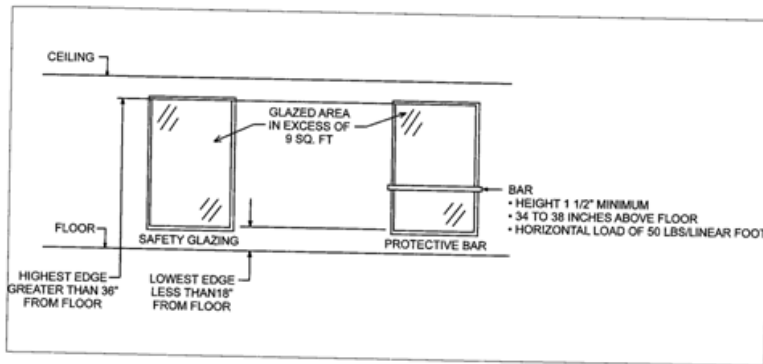

11. **At Stairs.** Walls, other than glass panels complying with IBC 1013 and 1607.7, enclosing stairway landings or within 60 inches of top or bottom of the stairs when bottom edge of glazing is less than 60 inches above walking surface.

## Windows and Doors - Safety Glazing

Page 4 of 4

### Exceptions include:

1. Doors with openings less than 3 inches.
2. Decorative glass for #1, #6 or #7.
3. Adjacent to doors away from the swing direction. Where there is an intervening wall or other permanent barrier between the door and the glazing.
4. Where access through the door is to a closet or storage area less than 3 feet deep.
5. Mirrors and other glass panels mounted or hung on a surface that provides a continuous backing support.
6. Glass block panel.

### 4. Site-built windows. (R308.5) Site built windows shall comply with Section 2404 of the Kentucky Building Code.

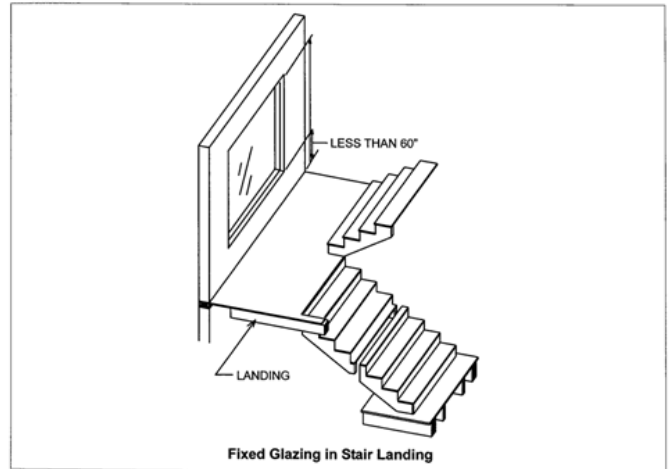

Figure 14-13

### 5. Skylights and Sloped Glazing.

- a. **Slope – (R308.6)** Slopes exceeding 15 or more degrees from vertical.

#### Types of Glazing Permitted:

1. **Laminated. (R308.6.2)** Glass laminated with minimum 0.015-inch polyvinyl butyral interlayer panes up to 16 square feet in area located with the highest point of the glass not more than 12 feet above a walking surface. For higher or larger sizes, the minimum interlayer thickness shall be 0.30 inch.
2. **Fully Tempered. With screen below. (R308.6.5)** The screen is not required for single glazing or the inboard pane of multiple glazing when:
  - a. Maximum 16 square feet and no higher than 12 feet above the walking surface and thickness not more than 3/16 inch. For multiple glazing, the other panes must be fully tempered, laminated or wired, or
  - b. Greater than 16 square feet, sloped no more than 30 degrees, and no higher than 10 feet above the walking surface.
3. **Heat-strengthened glass with screen below.**
4. **Approved rigid plastics.**
5. **Wired glass.**
  - **Greenhouses. (R308.6.6)** Any type of glass permitted to be installed without screening in the sloped area for green houses provided the ridge height does not exceed 20 feet above grade.
  - **Screen. (R308.6.7)** The screen and its fastenings shall be capable of holding twice the weight of the glass and have a maximum 1-inch mesh opening.
  - **Multiple Pane. (R308.6.4)** Glass with screen below for inboard panes of fully tempered, heat-strengthened and wired glass.
  - **Curbs. (R308.6.8)** Factory assembled skylight units installed on roofs flatter than 3:12 pitch shall be mounted on a 4-inch curb.

#### Bibliography.

The code references and graphics pictured are found in the following resources.

1. [Figure 14-10, Locations for Safety Glazing, 2003 IRC Performing Residential Building Inspections, this handout pg. 1 of 4.](#)
2. [Figure 208.4b, Safety Glazing in Tub and Shower Enclosures, Text KRC R308.4, this handout pg. 2 of 4](#)
3. [Figure 14-15, Tempered Safety Glass stamp, 2003 IRC Performing Residential Building Inspections, this handout pg. 2 of 4.](#)
4. [Figure 208.4c, Safety Glazing in Close Proximity to Doors, Text KRC R308.4, this handout pg. 2 of 4](#)
5. [Figure 14-11, Fixed Glass in Sidelights, 2003 IRC Performing Residential Building Inspections, this handout pg. 2 of 4.](#)
6. [Figure 208.4d, Safety Glazing for Fixed Panels, Text KRC R308.4, this handout pg. 3 of 4](#)
7. [Figure 14-9, Fixed Glass Adjacent to Walking Surface, 2003 IRC Performing Residential Building Inspections, this handout pg. 3 of 4.](#)
8. [Figure 14-13, Fixed Glazing in Stair Landing, 2003 IRC Performing Residential Building Inspections, this handout pg. 4 of 4.](#)